

OpenAir™

Air damper actuators

GEB..1E



Electronic rotary actuators for 2-position, 3-position, and modulating control



- Nominal torque 20 Nm
- Operating voltage AC 24 V ~ / DC 24...48 V = or AC 100...240 V ~
- Mechanically adjustable span between 0...90°
- Pre-wired with standard 0.9 m connection cables
- Type-specific variations with adjustable offset and span for the positioning signal
- Position indication: Mechanical and electrical
- Feedback potentiometer
- Self-adaption of the rotation angle range and adjustable auxiliary switches for supplemental functions

Use

Rotary actuators are used in ventilation and air conditioning plants to regulate and shut off air dampers:

- For damper areas up to approximately 4 m² (Guideline: Always comply with the damper manufacturer's specifications).
- Suitable for use with 2-position and 3-position controllers as well as modulating controllers (DC 0/2...10 V) to control air dampers.
- We recommend a minimum pulse length of 500 ms on rotary actuators operated with 3-point control to ensure continuous and accurate operation.

Functions

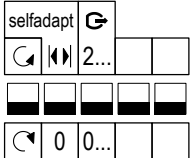
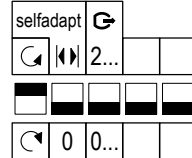
GEB..	AC 24 V ~ / DC 24...48 V –	141.1E / 142.1E / 146.1E	161.1E / 163.1E / 164.1E / 166.1E
	AC 100...240 V ~	341.1E / 346.1E	361.1E
Control type	2-position / 3-position		Modulating control (0/2...10 V)
Rotary movement, rotary direction	<p>Clockwise or counterclockwise direction depends ...</p> <p>... on the type of control</p> <p>... on the setting of the rotary direction switch.</p> <div style="display: flex; justify-content: space-around; align-items: center;"> <div style="text-align: center;"> <p>CW</p>  </div> <div style="text-align: center;"> <p>CCW</p>  </div> </div> <p>The actuator remains in the respective position with no power applied.</p> <p>cw = Clockwise ccw = Counterclockwise</p>		<p>... on the setting on the DIL switch clockwise / counterclockwise</p> <div style="display: flex; justify-content: space-around; align-items: center;"> <div style="text-align: center;"> <p>CW</p>  </div> <div style="text-align: center;"> <p>CCW</p>  </div> </div> <p>... on the positioning signal.</p> <p>The actuator remains in the deployed position:</p> <p>... if the positioning signal is maintained at a constant value</p> <p>... in the event of power loss</p>
Position indication Mechanical	Rotation angle position indication using a position indicator.		
Position indication Electric	By connecting the feedback potentiometer to external voltage, output voltage is generated proportional to rotation angle.	<p>Position indicator: Output voltage U = DC 0/2...10 V is generated proportional to rotation angle.</p> <p>The direction of rotation (inverted or non-inverted) for output voltage U is based on the DIL switch position.</p>	
Auxiliary switch	The switching points for auxiliary switches A and B can be set independently in increments of 5° from 0 to 90°.		
Self-adaptation of the rotation angle range	<p>The actuator automatically determines the mechanical end positions of the rotation angle range.</p> <p>The characteristic function (U₀, ΔU) is mapped to the calculated rotation angle range.</p> <p>Power must be connected to DIL switch 2 (self-adaptation) for the function to operate.</p>		
Manual adjustment	The actuator can be manually adjusted by pressing the gear train disengagement button.		
Rotation angle limitation	A set screw can limit the rotation angle to between 0° and 90°.		

Technical design

Housing

- Robust and light cast aluminum housing. The housing guarantees long life, even under harsh ambient conditions.

Actuator / gears

- Brushless, robust DC motors ensure reliable operation regardless of load. The damper actuators do not require an end position switch, are overload proof, and remain in place upon reaching the end stop.
- The gears are maintenance free and low noise.

Type summary

Type	Stock number	Open-loop control	Operating voltage	Positioning signal input Y	Position indicator U = DC 0...10 V –	Feedback potentiometer 5 kΩ	Self-adapting rotation angle ranges	Auxiliary switch	Rotation direction switch
GEB141.1E	S55499-D329	2- or 3-position	AC 24 V ~ / DC 24...48 V =	-	-	-	-	-	Yes
GEB142.1E	S55499-D330					Yes			
GEB146.1E	S55499-D331					-		2	
GEB341.1E	S55499-D336		AC 100...240 V ~			-		-	
GEB346.1E	S55499-D337					2			
GEB161.1E	S55499-D332	Modulating	AC 24 V ~ / DC 24...48 V =	DC 0/2...10 V =	Yes	-	Yes	-	Yes
GEB163.1E	S55499-D333			DC 0...35 V =				2	
GEB164.1E	S55499-D334			DC 0/2...10 V =				-	
GEB166.1E	S55499-D335		AC 100...240 V ~	-				-	
GEB361.1E	S55499-D338			-					

Accessories/spare parts

See data sheet N4697

Product documentation

Topic	Title	Document ID
Data sheet	Air damper actuators	A6V11449860
Technical principles	Non-spring rotary actuators GEB...1	Z4621
Mounting Instructions	GEB..1E	A6V11476940
Data sheet	Accessory and spare parts for air damper actuators	N4697

Related documents such as environmental declarations, CE declarations, etc., can be downloaded at the following Internet address:

<http://siemens.com/bt/download>

Safety



⚠ CAUTION

National safety regulations

Failure to comply with national safety regulations may result in personal injury and property damage.

- Observe national provisions and comply with the appropriate safety regulations.
- Mounting, commissioning, and service by properly trained personnel only.

Engineering

Auxiliary switch and potentiometer

Cannot be integrated after the fact.

Mounting

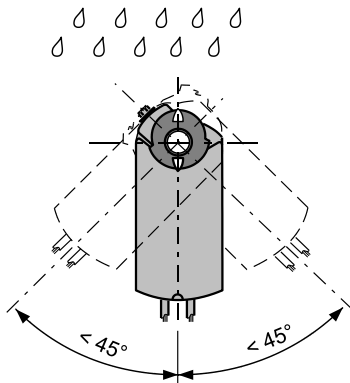

See Mounting instructions M4621

Shaft connection

When mounting, comply with the notes on shaft diameters and damper surface areas in Technical data (page 8) and use only quality materials typical to the sector for the damper shaft.

Installation



⚠ WARNING

No internal line protection for supply lines to external consumers

Risk of fire and injury due to short-circuits!

- Adapt the line diameters as per local regulations to the rated value of the installed fuse.

Maintenance

The GEB..1E actuators are maintenance-free.

Disposal



The device is considered an electronic device for disposal in accordance with the European Guidelines and may not be disposed of as domestic garbage.

- Dispose of the device through channels provided for this purpose.
- Comply with all local and currently applicable laws and regulations.

Technical data

Power supply (GEB1..1E)			
Operating voltage (SELV/PELV)		AC 24 V ~ ± 20 % (19.2...28.8 V ~) DC 24...48 V = ± 20 % (19.2...57.6 V =) ¹⁾	
Frequency		50/60 Hz	
Power consumption:	During operation	GEB14..1E GEB16..1E	2.3 VA / 1.1 W 2.5 VA / 1.2 W
	Holding	GEB14..1E GEB16..1E	0.5 W 0.65 W

Power supply (GEB3..1E)			
Operating voltage (SELV/PELV)		AC 100...240 V ~ ± 10 % (90...264 V ~)	
Frequency		50/60 Hz	
Power consumption:	During operation	GEB34..1E GEB36..1E	4 VA / 1.6 W 3.4 VA / 1.3 W
	Holding	GEB34..1E GEB36..1E	0.9 W 0.6 W

Function data	
Nominal torque	20 Nm
Maximum torque (when blocked)	35 Nm ²⁾
Minimum holding torque	20 Nm
Nominal rotation angle (with position indication)	90°
Maximum rotation angle (mechanically limited)	95° ± 2°
Runtime at nominal rotation angle 90°	150 s
Actuator sound power level (at a positioning time of 150 s)	<35 dB(A)

Inputs		
Positioning signal for GEB14..1E		
Operating voltage	(wires 1-6/G-Y1)	Clockwise
AC 24 V ~ / DC 24...48 V =	(wires 1-7/G-Y2)	Counterclockwise
Positioning signal for GEB34..1E		
Operating voltage	(wires 1-6/G-Y1)	Clockwise
AC 100...240 V ~	(wires 1-7/G-Y2)	Counterclockwise
Positioning signal for GEB16..1E		
Input voltage	(wires 8-2/Y-G0)	DC 0/2...10 V =
Power consumption		0.1 mA
Input resistance		>100 kΩ
Max. permissible input voltage		DC 35 V = limited internally to DC 10 V =
Protected against faulty wiring		Max. AC 24 V ~ / DC 24...48 V =
Hysteresis for non-adjustable characteristic function		60 mV
for adjustable characteristic function		0.6 % of ΔU
Adjustable characteristic (GEB163.1E, GEB164.1E)		
Adjustable with 2 potentiometers:	Offset U ₀	DC 0...5 V =
	Span ΔU	DC 2...30 V =
Max. input voltage		DC 35 V =
Protected against faulty wiring		Max. AC 24 V ~ / DC 24...48 V =

¹⁾ cUL: Only to DC 30 V = permissible

²⁾ See notes on page 4 and page 8

Outputs		
Position indicator		
Output signal (GEB16..1E)	(wires 9-2/U-G0)	
Output signal (GEB36..1E)	(wires 9-2/U-G-)	
Output voltage U		DC 0...10 V =
Max. output current		DC ± 1 mA
Protected against faulty wiring		Max. AC 24 V ~ / DC 24...48 V =
Aux. power supply (G-/G+)		
	GEB36..	DC 24 V = ± 20 %, max. 10 mA
Feedback potentiometer (for GEB142.1E)		
Change in resistance	(wires P1-P2)	0...5000 Ω
Load		<0.25 W
Max. contact current		<0.1 mA
Permissible voltage at potentiometer (SELV/PELV)		AC 24 V ~ / DC 24...48 V =
Insulation resistance between potentiometer and housing		AC 500 V ~

Auxiliary switches (GEB146.1E, GEB166.1E, GEB346.1E)		
Switching voltage		AC 24...250 V ~ / DC 12...30 V =
Contact loading		6 A resistive, 2 A inductive, min. 10 mA @ AC 4 A resistive, 2 A inductive, min. 10 mA @ DC 30 V = 0.8 A resistive, 0.5 A inductive, min. 10 mA @ DC 60 V =
Electric strength auxiliary switch against housing		AC 4 kV
Switching range for auxiliary switches / setting increments		5°...90° / 5°
Factory switch setting:	Switch A	5°
	Switch B	85°

Connection cables	
Cable length	0.9 m
Cross-section	0.75 mm ²
Permissible length for signal wires	300 m

Protection class and degree of protection	
Protection class	EN 60730
AC 24 V ~ / DC 24...48 V =, feedback potentiometer	III
AC 100...240 V ~, auxiliary switches	II
Degree of protection of housing	IP54 as per EN 60529 (see "Mounting", page 4, and Mounting instructions A6V11476940)

Environmental conditions	
Operation	IEC 60721-3-3
Climatic conditions	Class 3K5
Mounting location	interior, weather-protected
Temperature	-32...55 °C
Humidity, non-condensing	<95 % r.h.
Transportation	IEC 60721-3-2
Climatic conditions	Class 2K3
Temperature	-32...70 °C
Humidity, non-condensing	<95 % r.h.
Storage	IEC 60721-3-1
Climatic conditions	Class 1K3
Temperature	-32...50 °C
Humidity, non-condensing	<95 % r.h.
Mechanical conditions	Class 2M2

Standards, directives and approvals	
Product standards	EN60730 Part 2-14: Particular requirements for electric actuators
Electromagnetic compatibility (field of use)	For residential, commercial, and industrial environments
EU conformity (CE)	A5W00004376 ³⁾
RCM conformity	A5W00004377 ³⁾
UKCA conformity	A5W00198170A ³⁾
EAC compliance	Eurasian conformity
UL Federal Communications Commission	UL as per 60730 http://ul.com/database cUL as per CSA-C22.2 No. 24-93

Environmental compatibility
The product environmental declaration A5W00055607 ³⁾ contains data on environmentally compatible product design and assessments (RoHS compliance, materials composition, packaging, environmental benefit, disposal).

Dimensions	
Actuator (W x H x D)	See "Dimensions" (page 11)
Damper shaft	
Round	8...20.5 mm
Square (diagonal)	8...14.5 mm
Min. length	20 mm
Max. shaft hardness	<300 HV

Weight	
Excl. packaging	Max. 1.1 kg, without auxiliary switches Max. 1.3 kg, with auxiliary switches

³⁾ Documents can be downloaded at <http://siemens.com/bt/download>.

!	NOTICE
	<p>Shaft connection – Important notes for the manufacturer / installer</p> <p>Use of unsuitable damper shafts may damage the damper or damper shaft.</p> <ul style="list-style-type: none"> ● Use only damper shafts with diameters suitable for the damper surface. ● Use only quality materials typical for the sector for damper shafts/rods.

Internal Diagrams

GEB14..1E

(open-close, 3-position control)

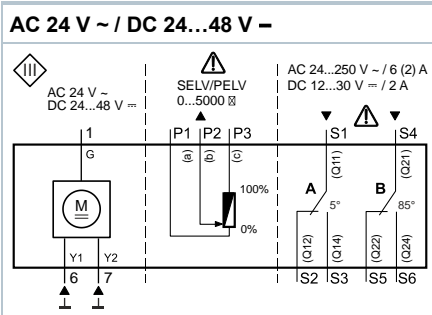

GEB34..1E

(open-close, 3-position control)

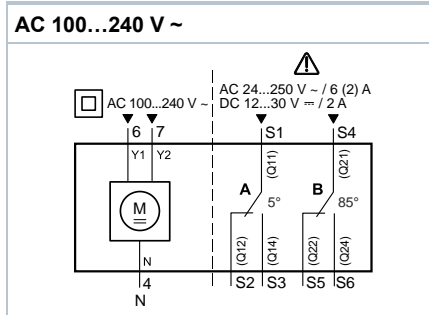

GEB16..1E

(modulating, Y = DC 0/2...10 V =)

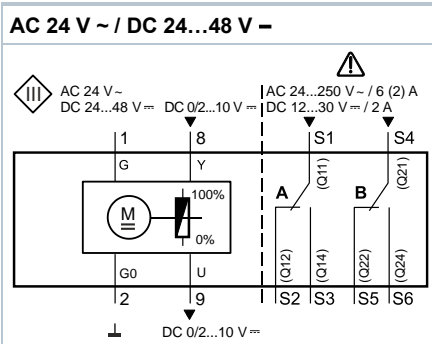

GEB16..1E

(modulating, Y = DC 0...35 V =)

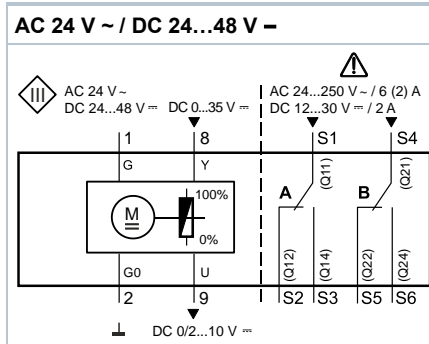

GEB361.1E

(modulating, Y = DC 0/2...10 V =)

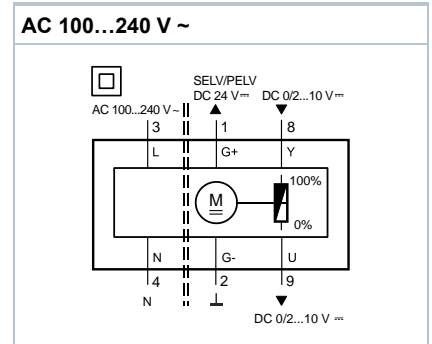

Connection diagrams

Control on GEB1..1E (AC 24 V ~ / DC 24...48 V =)

Open-close, single wire control Single pole single throw (SPST)	Open-close, double wire control Single pole double throw (SPDT)	3-position control	Modulating control
<p>AC 24 V ~ / DC 24...48 V =</p>	<p>AC 24 V ~ / DC 24...48 V =</p>	<p>AC 24 V ~ / DC 24...48 V =</p>	<p>AC 24 V ~ / DC 24...48 V =</p>
<p>AC 24 V ~ / DC 24...48 V =</p>	<p>AC 24 V ~ / DC 24...48 V =</p>	<p>AC 24 V ~ / DC 24...48 V =</p>	

Control on GEB3..1E (AC 100...240 V ~)

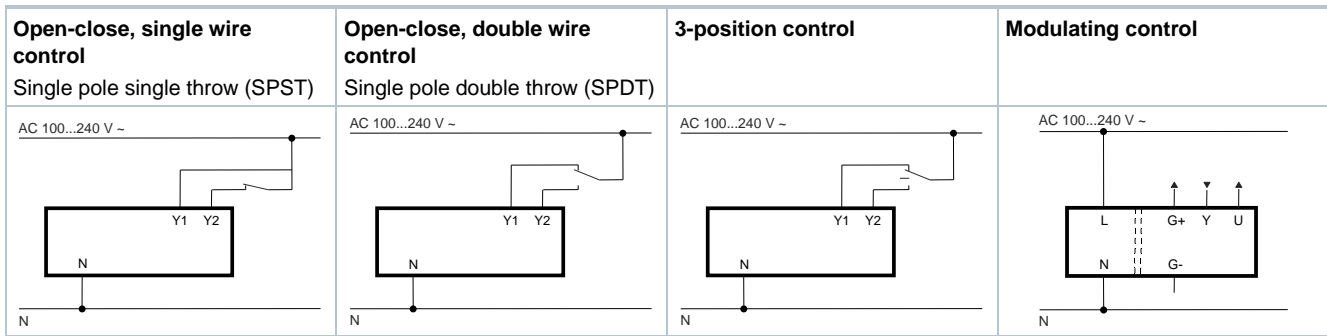

Cable designations

Connecting thread	Code	No.	Color	Abbreviation	Meaning
Actuators AC 24 V ~ / DC 24...48 V =	G	1	red	RD	System potential AC 24 V ~ / DC 24...48 V =
	G0	2	black	BK	System zero
	Y1	6	violet	VT	Positioning signal AC/DC 0 V, clockwise (GEB14..1E)
	Y2	7	orange	OG	Positioning signal AC/DC 0 V, counterclockwise (GEB14..1E)
	Y	8	gray	GY	Signal input (GEB16..1E)
	U	9	pink	PC	Signal output (GEB16..1E)
Actuators AC 100...240 V ~	L	3	brown	BR	Phase, AC 100...240 V ~
	N	4	light blue	BU	Neutral conductor
	Y1	6	black	BK	Positioning signal AC 100...240 V ~, clockwise (GEB34..1E)
	Y2	7	white	WH	Positioning signal AC 100...240 V ~, counterclockwise (GEB34..1E)
	G+	1	red	RD	System potential DC 24 V (auxiliary power) (GEB361.1E)
	G-	2	black	BK	System neutral (auxiliary power) (GEB361.1E)
	Y	8	gray	GY	Signal input (GEB361.1E)
	U	9	pink	PK	Signal output (GEB361.1E)
	Feedback potentiometer	a	P1	white/red	WH RD
b		P2	white/blue	WH BU	Potentiometer pick-off
c		P3	white/pink	WH PK	Potentiometer 100...0 % (P3-P2)
Auxiliary switch	Q11	S1	gray/red	GY RD	Switch A input
	Q12	S2	gray/blue	GY BU	Switch A NC contact
	Q14	S3	gray/pink	GY PK	Switch A NO contact
	Q21	S4	black/red	BK RD	Switch B input
	Q22	S5	black/blue	BK BU	Switch B Normally closed contact
	Q24	S6	black/pink	BK PK	Switch B NO contact

Dimensions

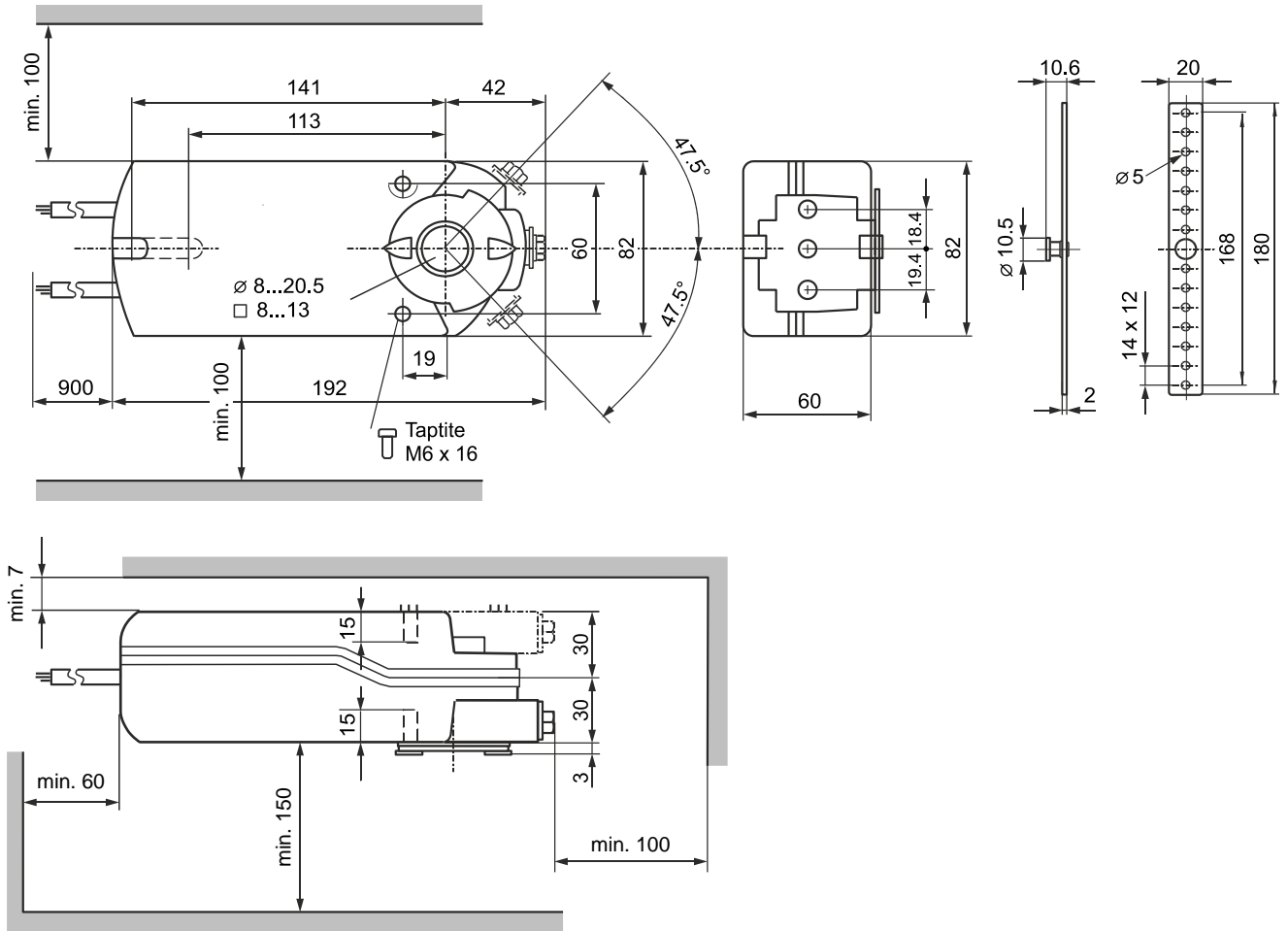

Dimensions in mm

Revision numbers

Type	Valid from rev. no.	Type	Valid from rev. no.
GEB141.1E S55499-D329	..A	GEB164.1E S55499-D334	..A
GEB142.1E S55499-D330	..A	GEB166.1E S55499-D335	..A
GEB146.1E S55499-D331	..A	GEB341.1E S55499-D336	..A
GEB161.1E S55499-D332	..A	GEB346.1E S55499-D337	..A
GEB163.1E S55499-D333	..A	GEB361.1E S55499-D338	..A

Issued by
Siemens Switzerland Ltd
Smart Infrastructure
Global Headquarters
Theilerstrasse 1a
6300 Zug
Switzerland
Tel. +41 58-724 24 24
www.siemens.com/buildingtechnologies

© Siemens Switzerland Ltd, 2019
Technical specifications and availability subject to change without notice.